

DPM Mats



Features

- Custom shapes & sizes
- Aluminium diamond plate surface
- Aluminium ramped edging
- Optional sensitivities
- Fail-safe operation
- Multiple switching zones available
- Extremely heavy duty
- Withstands heavy traffic

The DPM mat system has extremely high durability in the harshest of industrial environments. The mat gives excellent resistance to impact and is particularly useful in applications where hot materials falling on the mat would damage a conventional construction. The system comprises a Tapeswitch safety mat fitted below an aluminium diamond plate construction, which is held in position by extruded aluminium edge strips. The system is manufactured to the required size and despatched in kit form to be assembled on-site.

As with all our mats, the DPM range be made in custom shapes and sizes to suit a wide variety of applications.

Technical Specification

Surface material	6061 T6 aluminium
Dimensions	On request
Depth	approx. 20mm
Actuation force	<300N (30kg) (80mmø test piece)
Response time	25ms
Inactive area	90mm around outer edge
Protection rating	IP65
Weight	32kg/m ²
Operating temperature	0°C to +50°C
Operating voltage	24V d.c.
Operating current	1A
Power consumption	6VA

Construction

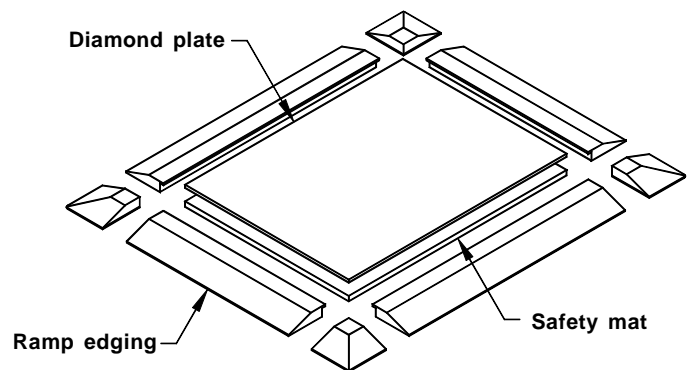

Typical Applications

- Machinery safety
- Interactive
 - Play zones*
 - Theme parks*
 - Advertising*
- Access control
 - Banks*
 - Intruder alert*
 - Transport doors*

GB-02/05

Tapeswitch Ltd

Unit 38 Drumhead Road Chorley North Industrial Park Chorley Lancashire England PR6 7BX
 Tel Int +44 01257 249777 Fax Int +44 01257 246600 E-mail info@tapeswitch.co.uk Website www.tapeswitch.co.uk